

# MR-compatible camera “12M *newSensor*”

## User manual

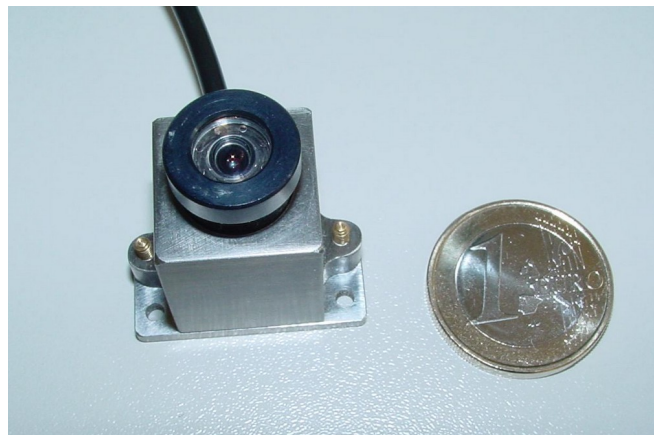

### 1. Intended use

Our MR compatible video cameras are designed to view and record video images of subjects in an MR scanner. They can also be used for the monitoring of objects and instruments. The cameras can be used inside the bore of the scanner. They can be equipped with different exchangeable lenses. The correct orientation of the cables, the correct installation of the filter box, and the correct grounding should be checked before the application. Respective descriptions can be found in this user manual.

The cameras are tested in MR scanners with static fields of up to 7T, higher fields may be possible too.

The cameras are not equipped with an automatic alert in case of an interruption of the video stream. That is why they are not intended to identify critical states or situations.

### 2. System components

- Camera
- Filter box *newSensor* (with optical isolation of video signal). This is not compatible with the former model!
- Camera connection cable (length: 10 m, 2 m at the camera + 8 m elongation cable)
- Power supply (length: 1.8 m)

- BNC cable (length: 2 m)
- BNC/Cinch adapter
- Earth ground cable for provisional installation

### 3. Video camera and lens

Figure 1 shows the camera housing and the connected lens.

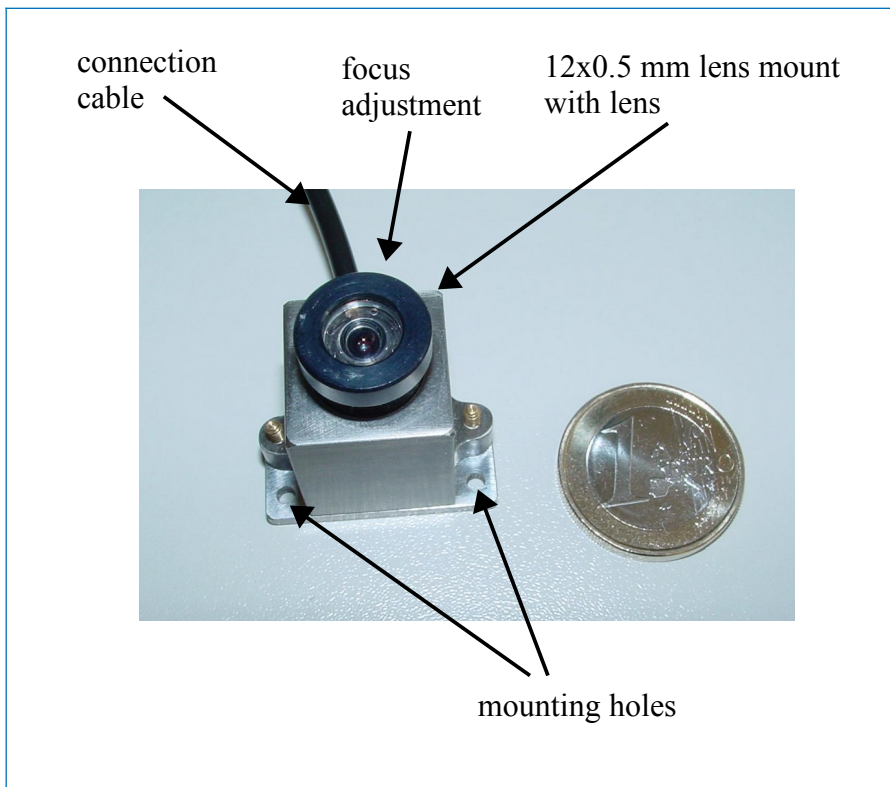

*Figure 1:  
Video camera with lens*

The lens is connected to the standard **M12 mount** in the housing.

- The **focus adjustment** is done by screwing the lens in and out. Care should be taken not to screw out the lens too far, as the lens may fall out of the thread.

The camera is connected to the filter box via a connection cable which must be plugged into the “**MR CAM Signal IN**” connector.

It can be mounted directly to any suitable object via the two 2 mm holes in the camera backplate.

## 4. Mounting options

Standard mounting options are:

1. direct mounting of the camera using the mounting holes
2. use of a ball joint mount (optional accessory) e.g. for use inside the MR bore
3. use of an articulated arm (optional accessory) for mounting the camera e.g. to the head coil
4. use of a mirror mount (optional accessory) to observe the eyes or the face inside the head coil
5. use of a tripod adapter (optional accessory) for mounting the camera on a tripod

You can find photos of the optional accessories in section 10 of this manual.

## 5. Connection of camera to filter box

The camera is connected to the filter box via the camera connection cable, which includes power and signal lines as well as shielding.

The filter box prevents the transmission of disturbing signals into the MR cabinet. It avoids interferences in the video signals and the MRI imaging.

The filter box includes a low pass filter that suppresses frequencies higher than 1 MHz with over 100 dB. This filter prevents damage and interferences caused by the high frequency signals of the MR scanner. Additionally an optical isolation is included in the filter box. In that way a full separation of the MRI equipment from the external power network is guaranteed.



*Figure 2: Filter box (front side)*

## 6. Filter box installation

The filter box should be mounted at the filter panel board of the MR room. It has to be placed outside of the MR room, The cable between camera and filter box has to be routed through a hole into the MR room.

For a permanent installation, the filter box should be screwed onto the panel board by means of the feed through **camera connector** (see figure 2). Figure 3 illustrates the recommended configuration:

- A 12 mm through hole in the panel board is required.

- The **camera connector** is guided through this hole.
- The camera connector provides the ground connection to the shielding of the MR cabinet.

For temporary use, the camera cable can be brought into the MR cabinet by other means, e.g. through a service entry hole (“waveguide”). In this case, an additional grounding cable should be used to connect the camera connector to the shield panel grounding. The camera connector must completely protrude into the MR cabinet and the video cable must not jut out.

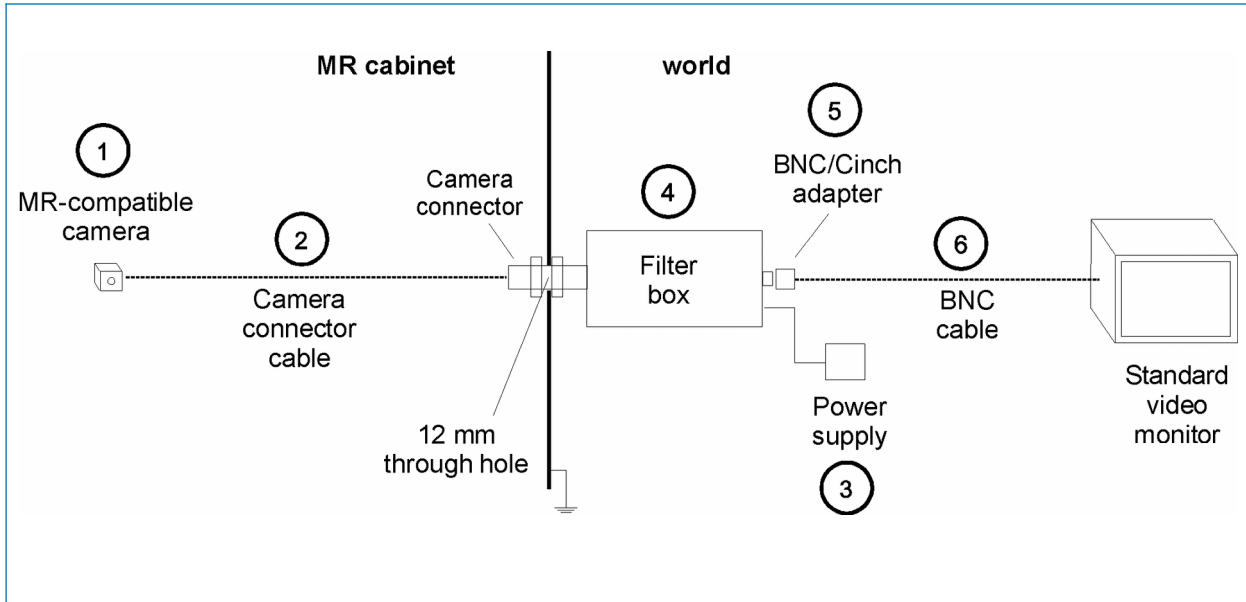

Figure 3: Device and cable configuration

## 7. Connection of power supply

The power for the camera is transmitted via the video cable. Therefore, the power supply is connected to the filter box (see figure 4).

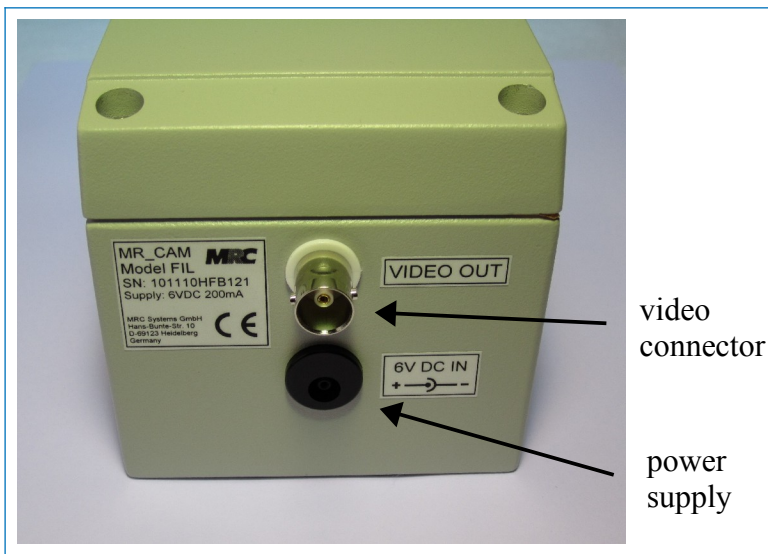

Figure 4: Filter box (rear side)

## **8. Connection of TV set, VCR, frame grabber, or video card**

A BNC/Cinch adapter and a standard BNC cable are used to transfer the video output signal to a TV set, VCR, frame grabber, or video card. The BNC cable is plugged via the adapter to the video connector at the filter box (see figure 4).

The video signal can be directly viewed with a TV set or recorded with a VCR. To view and store the images with a PC, the BNC/Cinch cable must be connected via an analog frame grabber card to the PC. Any software for analog video viewing should be appropriate to process the signals.

## **9. Maintenance and cleaning**

The device should be applied in dry environments. It is not sealed against splash water and rinsing liquids.

The housing and the lens can be cleaned with a dry cloth. If this is not sufficient, the cloth can be moistened with clear water or alcohol.

## 10. Technical data

Sensor Type: Color CMOS Sensor 1/4 inch, active sensor size: 4.1 mm x 3.1 mm  
Output: NTSC video signal with 60 Hz half frame rate  
or PAL video signal with 50 Hz half frame rate

### Spectral sensitivity

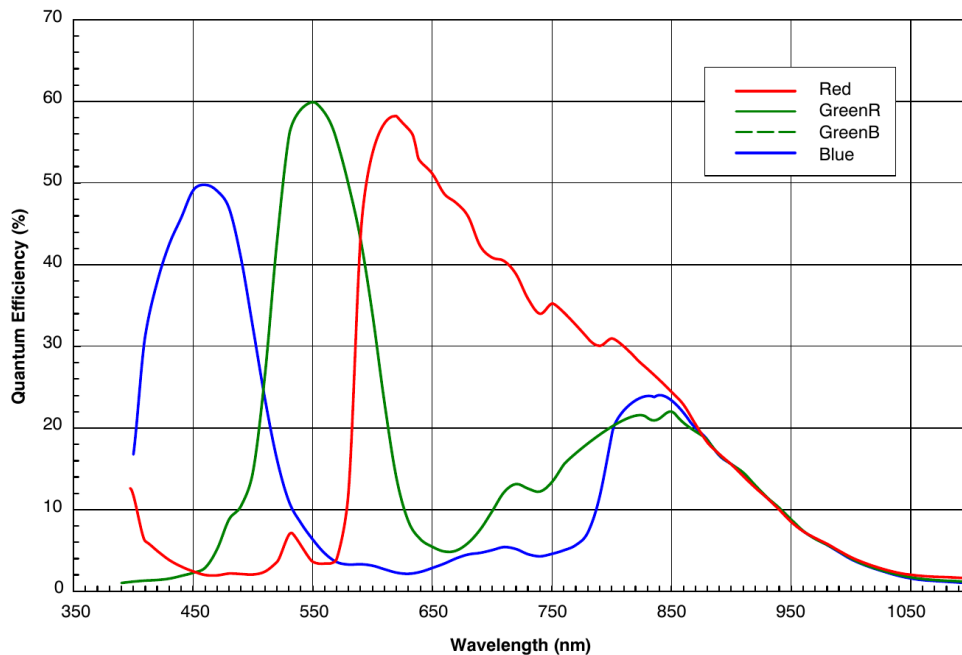

### Housing dimensions

Dimensions: 28 mm x 18 mm; height  $\approx$  23 mm + lens (with mounting bracket)  
Connector for lens: 12 x 0.5 mm mount  
Mounting thread: 2x 2 mm  $\varnothing$ , distance 23 mm  
Weight: 22 g

### Lenses

Type: fixed focal length with fixed aperture, exchangeable  
Mount: 12 x 0.5 mm  
Focal length: a big number of different focal lengths are available  
Standard delivery: focal lengths: 4 mm, 6 mm, 8 mm (other lenses on request)  
Aperture: e.g. 2.4  
Sensor format: 1/4 inch, active sensor size: 4.1 mm x 3.1 mm  
Minimal object distance: 50 mm (typical, depending on the chosen lens)

### Electronics

Power supply: 200 mA, 5.9-6.3 V DC  
Output impedance: 75  $\Omega$   
Type: Friwo FW8001M/06, 5.9 V (medical power supply)

### Filter box

Dimensions: 80 mm x 120 mm x 80 mm  
Weight: approx. 700 g

## 11. Accessories

We offer different camera holders and light sources as accessories to the MR compatible camera. Examples are shown in the photos below. We can also produce customised solutions. More information can be found in the specific product descriptions.

On request, we can also offer additional equipment like video cards.

### Camera holders

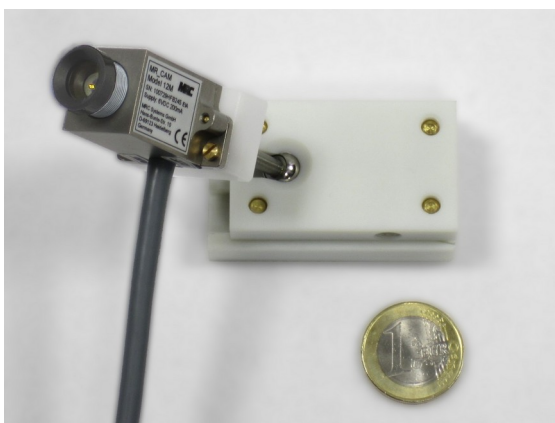

*Camera holder with ball joint for easy alignment*

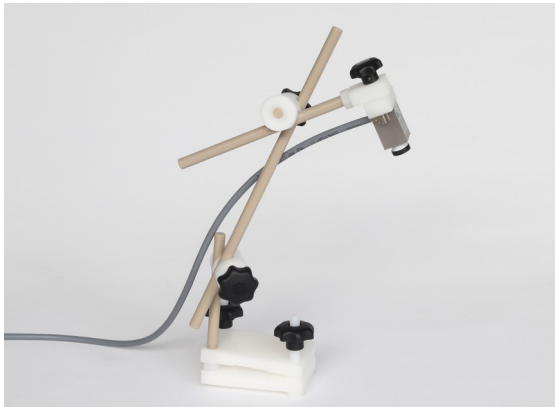

*Flexible camera holder based on articulated arm*

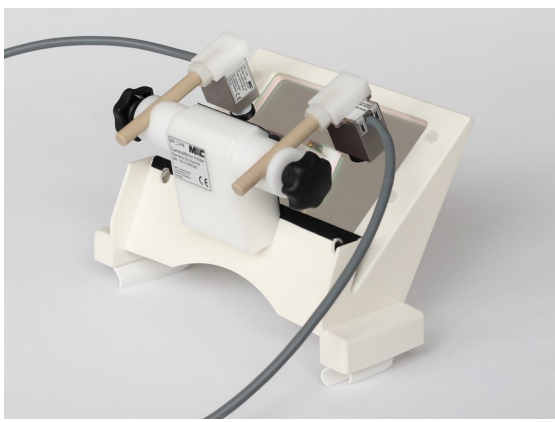

*Camera holder with mirror for MR head coil*

*Figure 5: Selection of MR compatible camera holders*



## LED light source

For applications of the video camera in dark environments we offer a compact light source with infrared or white light. It can be mounted next to the camera by means of a plastic fixture.

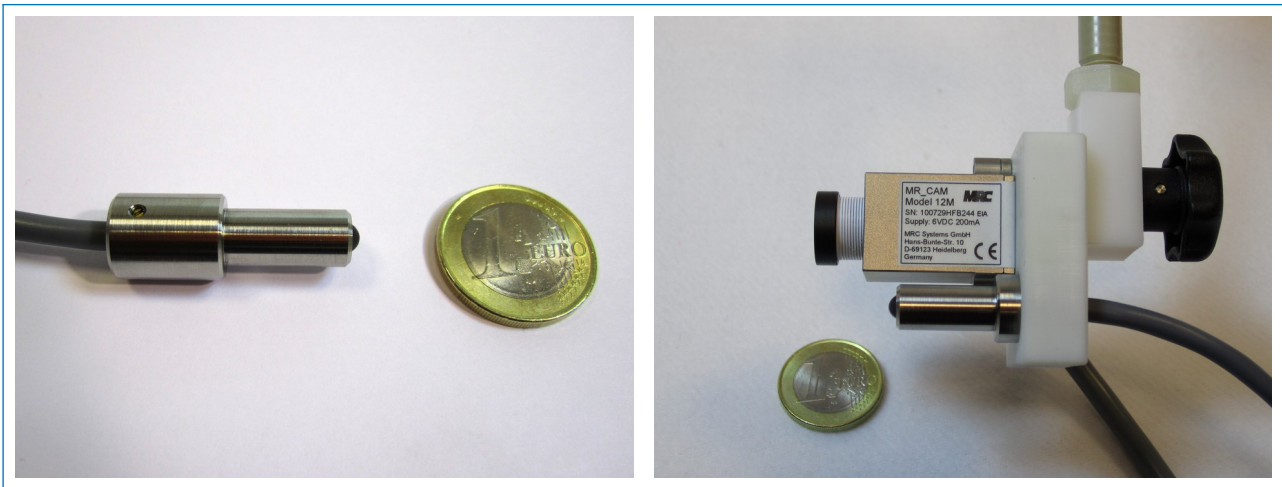
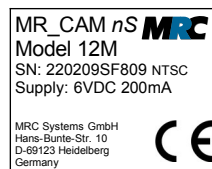
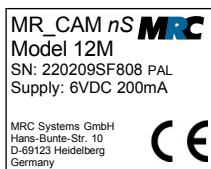

Figure 6: MR compatible LED light source, in the right photo mounted to the articulated arm besides the video camera

## 12. Labelling

A label on the camera housing includes the information about the embedded video sensor (color: PAL[50Hz], NTSC[60Hz]). The following copies are enlarged:



In addition, there is a label on the filter box:

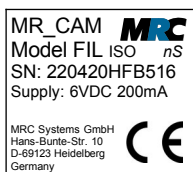

## 13. Contact

MRC Systems GmbH  
Hans-Bunte-Strasse 10  
D-69123 Heidelberg  
Germany  
phone: +49-6221-13803-00  
fax: +49-6221-13803-01  
mail: [info@mrc-systems.de](mailto:info@mrc-systems.de)