

# Data sheet

## P4S30 Piezo steering mirror mount



### P4S30

- Highest accuracy and greatest dynamics
- Large piezo tilting range ( $\pm 4$  mrad optical)
- Ideal for small and large mirrors

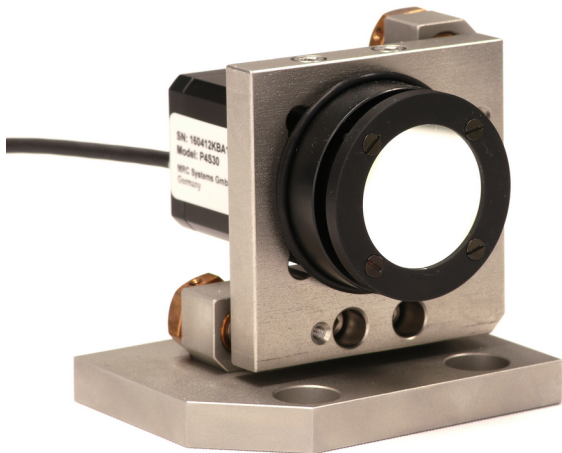

P4S30 steering mirror mount with 1 inch mirror

### Product description

The P4S30 piezo steering mirror mount is used to correct and stabilize laser beams. It consists of a piezo-driven 2D actuator and a mirror mount specially designed for dynamic applications. With four piezo stacks counter-tensioned in the actuator, the P4S30 offers highest positioning accuracy and speed. Furthermore, it has a high stiffness due to the stainless steel components used. This leads to highest resonant frequencies and consequently highest stabilization bandwidths.

The P4S30 can be equipped with adapters for different mirror sizes. This allows the user to fix common laser mirrors in a stable way as with ordinary mirror mounts. For pre-adjustment, the mirrors can also be tilted manually by means of fine-thread screws.

A clean room variant as well as a variant for applications in vacuum with a pressure of down to  $10^{-6}$  mbar are available.

### Specifications

Maximum tilt (mechanical)	4 mrad ( $\pm 2$ mrad)
Maximum tilt (optical)	8 mrad ( $\pm 4$ mrad)
Manual tilting	$\pm 4.5^\circ$
Number of piezo stacks	4
Operating voltage range	- 45 to 180 V
Capacity of piezo stacks	3.1 $\mu$ F
Resolution	optimized for use with MRC's beam stabilization
Resonant frequency	> 1200Hz *
Stabilization bandwidth	> 300Hz *
Possible mirror diameters	1, 1.5, 2 and 3 inch
Mirror thickness	from 3 mm
Beam height	40 mm
Operating temperature	- 30 to 80 °C

\* measured with 1" mirror and 1/4" mirror thickness

### General data

Material	Stainless steel, spring steel, etc.
Dimensions (H x W x D)	63 x 67.5 x 58.3 mm
Weight	545 g (with cable)
Cable / connector	2 m (fixed at actuator) / Lemo FFA.0S.304.CLAC32

# Data sheet

## P4S30 Piezo steering mirror mount



### Technical drawings

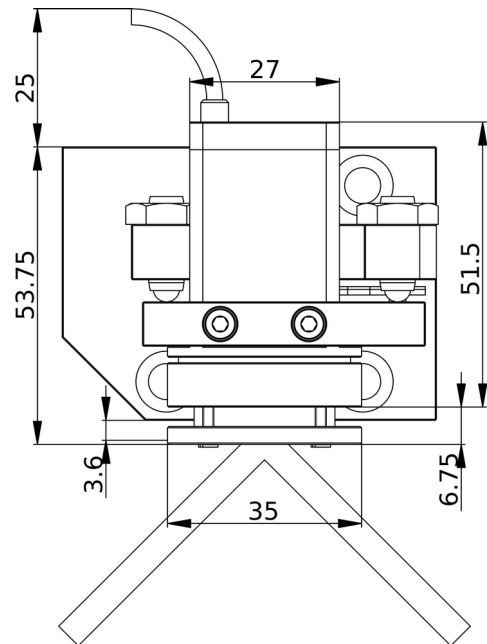
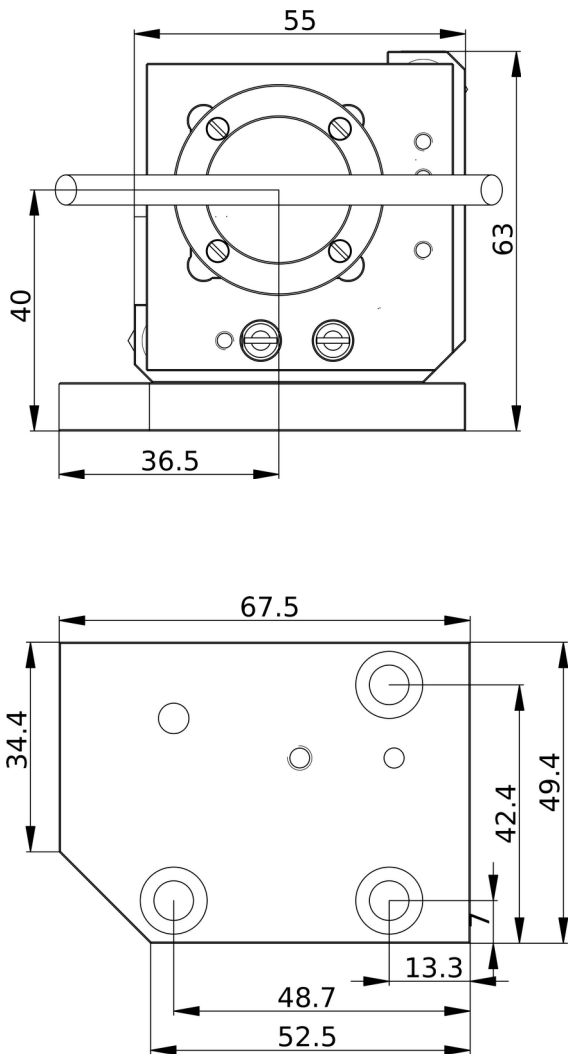

For further details please ask for the 3D STEP files.

### Pin configuration LEMO FFA.0S.304.CLAC32

LEMO	Signal
Pin 1	Y signal
Pin 2	X signal
Pin 3	HV DC (120 V)
Pin 4	GND



### Contact

MRC Systems GmbH  
 Hans-Bunte-Str. 10  
 D-69123 Heidelberg, Germany  
 Phone: +49(0)6221/13803-00  
 Email: info@mrc-systems.de

Subject to change without prior notice.